

FlensTech

Operating instructions Airflow Monitoring System F830415 & F830421



This instruction manual describes the use of the FlensTech airflow monitoring system. Please read these instructions before installing. If you have any questions, please contact FlensTech:

info@flenstech.de

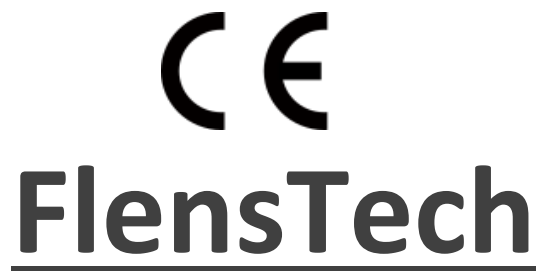

EU Declaration of Conformity

We hereby declare that the design and construction of the following product complies with the basic guidelines on health and safety requirements resulting from the EU Directive for Machinery 2006/42/EC.

Manufacturer:

FlensTech GmbH
Gewerbepark 3
D-24983 Handewitt
Germany
Phone: +49(0)175-3751 062

Harmonised standards applied:

ISO 12100:2011-03 (Risk assessment and risk reduction)

Details of the person responsible:

Name: Hans Christian Madsen
Position: Managing Director

Place, date

Signature

Overview

1	Description	2
1.1	Determination	2
1.2	Technical description of the environment	2
1.3	General	2
1.4	Representation	3
1.4.1	System	3
1.4.2	Dimensions	3
1.4.3	Specifications	3
1.5	Scope of delivery	4
2	Safety precautions	5
3	Description	6
4	First commissioning	7
5	Maintenance	10
5.1	Regular checks	10
5.2	Cleaning	10
6	Spare parts and accessories	11
7	Electrical diagrams	12
7.1	Complete connection scheme: PLX / PLC operation	12
7.2	Complete connection scheme: Mains operation	13
7.3	Detail A: PLX connectors	14
7.4	Detail B: Light tower connections	15
7.5	Detail C: Pressure transmitter connections	15
7.6	Detail D: PLC connections	16
8	Assembly sketches	17
8.1	Control box	17
8.2	Differential pressure transmitter and switch	18
8.3	Light tower and fixing plate	18
9	Change Log	19

1 Description

1.1 Determination

The FlensTech airflow monitoring system serves as a central distribution unit for signal delivery for monitoring and control devices. For this purpose, defined devices are connected to a central terminal block according to a predefined scheme. All signals are available to a higher-level PLC for optional processing.

The use is limited to industrial environments as well as technical laboratories.

The F830415 version is designed for use with Tantec PLX devices. With version F830421, a stand-alone operation without PLX nor PLC is possible.

1.2 Technical description of the environment

Ambient temperature: +10 to +40 °C

Humidity, relative: max. 70%, non-condensing

1.3 General

The information in this data sheet refers to our state of knowledge and the component versions at the time of publication. We reserve the right to make changes to the components or the data sheet. For the current versions, please contact us.

The airflow monitoring system sees itself as a tool. FlensTech cannot assume responsibility for complying with applicable maximum workplace concentrations. The buyer is responsible for the correct installation and use. Please regularly check the effectiveness of the entire extraction system. In addition, observe the applicable guidelines and limits for your operating environment. The same applies to the protection of other machine elements – for example due to corrosion because of ozone exposure.

All documents and designs are the intellectual property of FlensTech GmbH. Publication or disclosure, in particular of design information, is prohibited.

1.4 Representation

1.4.1 System



1.4.2 Dimensions

Element	Height/Length	Width	Depth	Assembly
Control box	192/250mm	164mm	105mm	4x Ø5 mm
Differential Pressure Transmitters	112mm	126mm	50mm	4x Ø4 mm
Light tower	310mm	Ø70mm		4x Ø5 mm
cables	5m			Connected
Hose	1m			Plug-in sleeve

1.4.3 Specifications





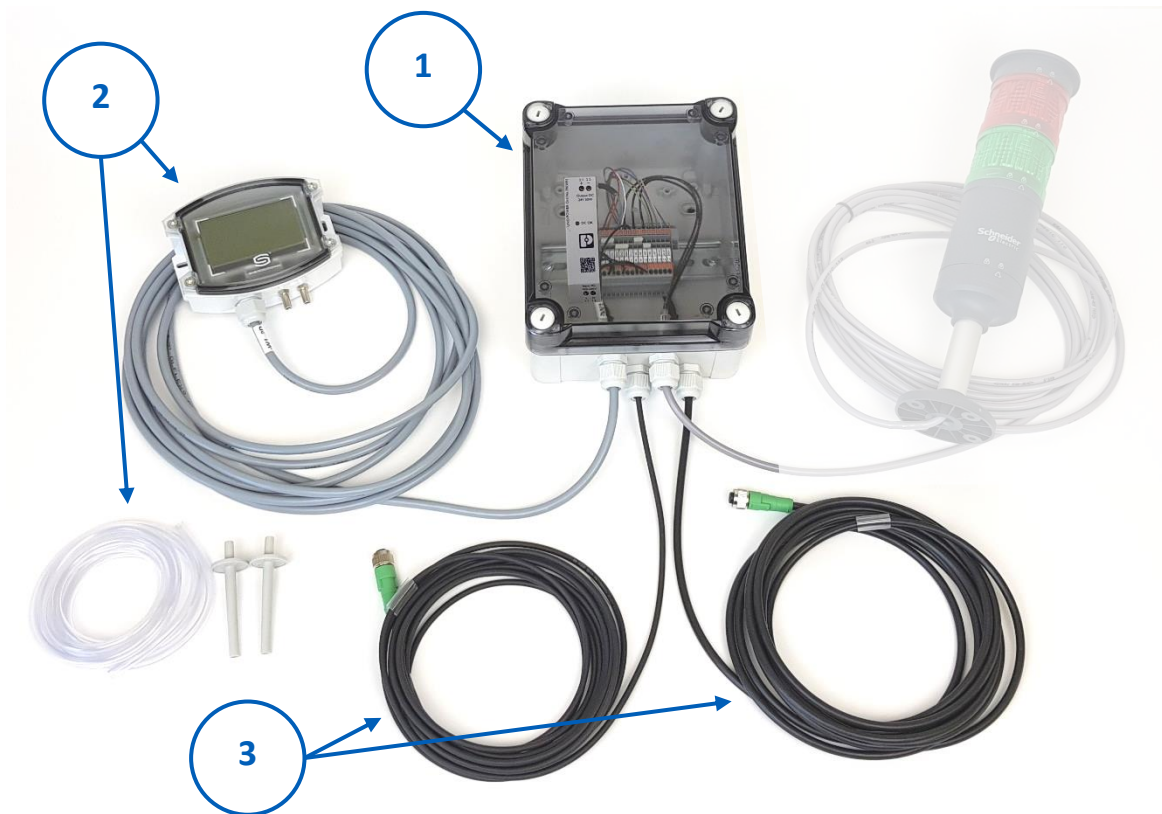



<p>Weights Control box incl. differential pressure transmitter and cables: 1.6 kg (optional) Light tower incl. cable: 450 gr.</p>
<p>Protection classes according to manufacturer's specifications Housing: IP 66 Differential pressure transmitter: IP 65 Signal traffic light: IP 65</p>
<p>Mounting type Wall/Rail 8</p>

1.5 Scope of delivery



Pos	Number	Designation
1	1	Control box
2	1	Differential pressure transmitter, 5m, connected Incl. 1m hose and two connection nipples
Variants		
3	2	for F830415 Control cables for PlasmaTEC-X, 5m
3	1	for F830421 Mains cable, 5m

2 Safety precautions

<p>The tip of a plasma nozzle can reach temperatures of up to 300°C. For this purpose, the information provided by the manufacturer of the plasma nozzle must be observed.</p>	
<p>The system hood serves as an aid for extracting ozone and nitrogen oxides. For this purpose, the information provided by the manufacturer of the plasma nozzle must be observed.</p>	
<p>To ensure that the plasma source is only active when the extraction system is operating at sufficient power, we recommend permanent pressure or air flow volume monitoring in the suction line. For this purpose, the information's provided by the manufacturer of the plasma nozzle and extraction hood must be observed.</p>	
<p>In order to ensure that the toxic gases are removed from the pipe, the extraction shall continue to operate for a reasonable period of time after the ozone and/or nitrogen oxide source has been switched off. The duration depends on the length of the lines and flow velocities inside. For work on the hood, the duration should be at least a few seconds.</p>	
<p>In the event of a fire, harmful gases can emanate from the hood (ABS/PC) and the connection (PA6).</p>	
<p>When treating loose substrates (e.g. cardboard boxes or sleeves), the substrate can be sucked in if the suction power is too high. Due to the lack of movement, the substrate can burn or ignite.</p>	
<p>In the treatment of loose, electrically conductive substrates (e.g. cardboard boxes or sleeves), the substrate can be sucked in if the suction power is too high. As a result, an electrical potential could be transferred from the plasma nozzle to the substrate.</p>	
<p>To ensure the functionality of the entire system, we recommend measuring the (residual) emissions under real production conditions. Even after changes to the system, such a control measurement is recommended.</p>	
<p>Changes to the lines are only to be made by expert personnel and with the help of these instructions.</p>	

3 Description

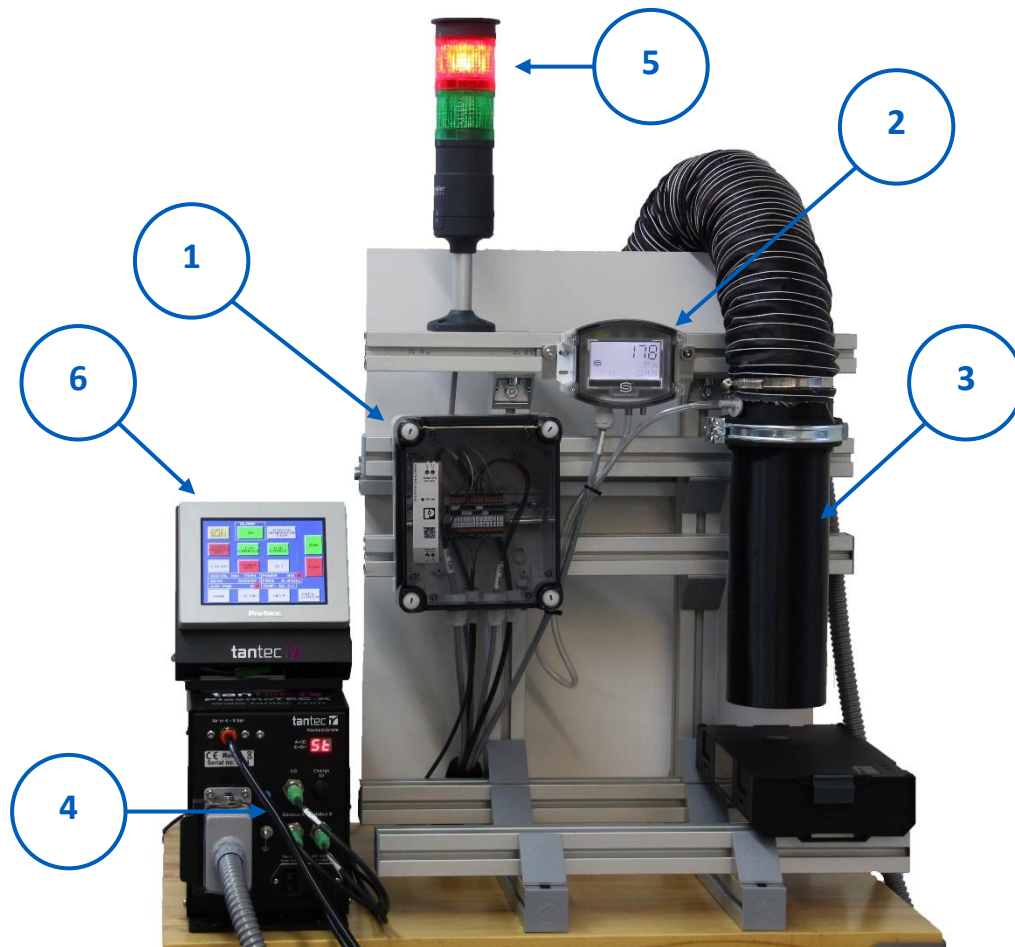

- | | | | |
|---|------------------------------------|---|--------------------|
| 1 | Control box | 4 | PLX Terminal |
| 2 | Differential Pressure Transmitters | 5 | Signal light tower |
| 3 | System hood | 6 | PlasmaREMOTE |

Plasma treatment produces corrosive and toxic gases which are detected and discharged via the FlensTech system hood (3). To ensure sufficient suction power, the line vacuum within the suction line is monitored by a pressure sensor (2). The control box (1) is used to supply this sensor with the required operating voltage and to display the status of the extraction via an optional signal light tower (5). Furthermore, the plasma generator (4) is controlled in such a way that activation of the plasma can only take place with sufficient negative pressure. The terminal of the control box also offers all connections for the PLC control of the plasma generator, so that easy integration or retrofitting is possible.

It should be noted that there is no monitoring whether the inlet is clogged – for example, because of a sucked-in, flat substrate. This can be retrofitted with an additional pressure sensor.

4 First commissioning

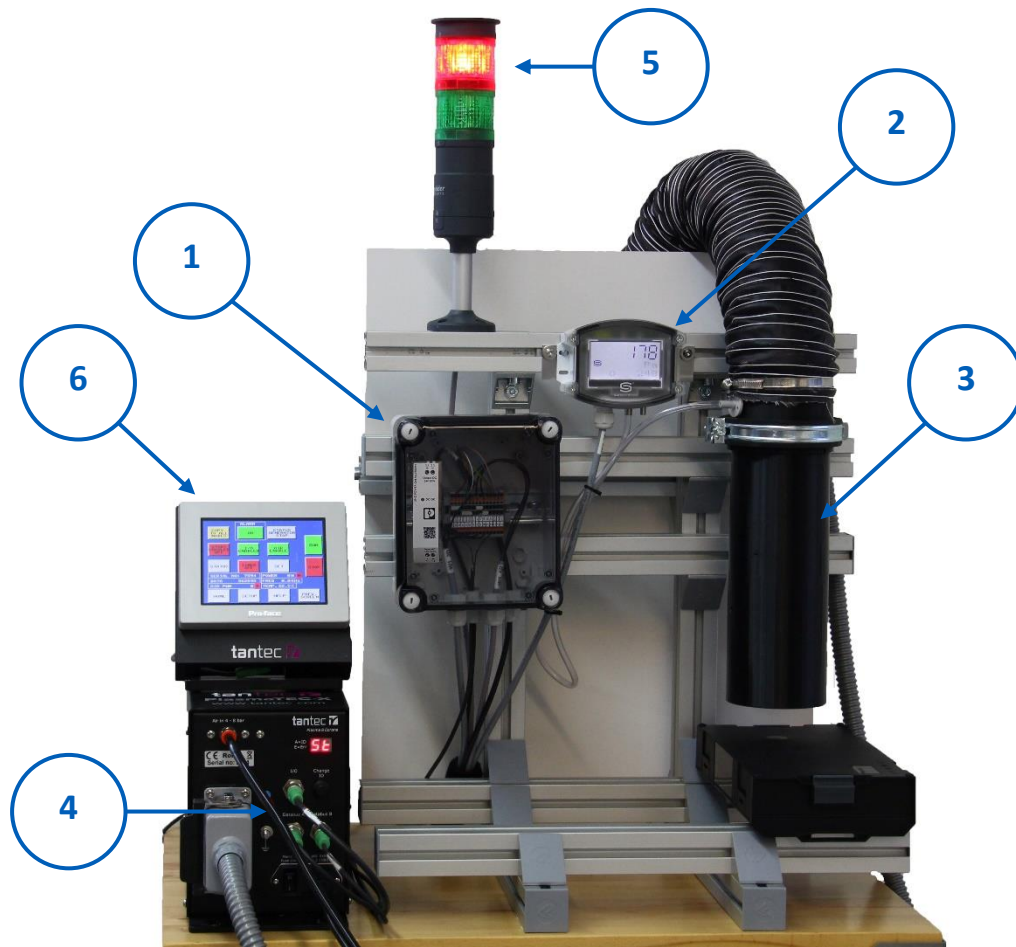

- | | | | |
|---|------------------------------------|---|--------------------|
| 1 | Control box | 4 | PLX Terminal |
| 2 | Differential Pressure Transmitters | 5 | Signal light tower |
| 3 | System hood | 6 | PlasmaREMOTE |

1. Mount the control box (1) on a wall or frame according to the manufacturer's specifications.
2. Mount the differential pressure transmitter (2). A optimal position allows the display to be easily recognized and accessible for the setting of the pressure switching point under step 8.
3. Mount the connection nipple on the system hood (3) according to the manufacturer's instructions.
4. (optional) Mount the signal traffic light (5). If you install the signal traffic light subsequently, connect the cables according to the electrical connection plan from Chapter 7
5. **Only for PLX variant:** Connect the control cables to the PlasmaTEC-X (4). Connect all other cables according to the manufacturer's instructions.

6. For PLX multi – with PlasmaREMOTE (6):

Place a bridge on contacts 11 | NO and 12 | INT in the terminal.

Activate "Start Enabled", "I/O Enabled" and "Air Enable" on the PlasmaREMOTE – all three fields are green as shown in the following image. For more information, please refer to the manufacturer's operating instructions.

The discharge can now be controlled as usual via "Start" and "Stop".

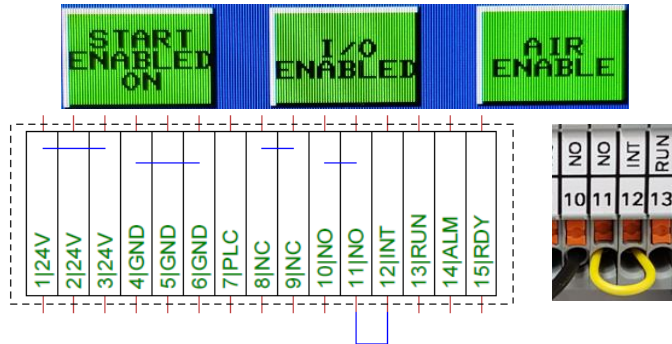

7. For PLX OEM – without PlasmaREMOTE:

The control box provides all I/O signals of the PlasmaTEC-X. Connect your PLC to the terminal of the control box according to the following plan.

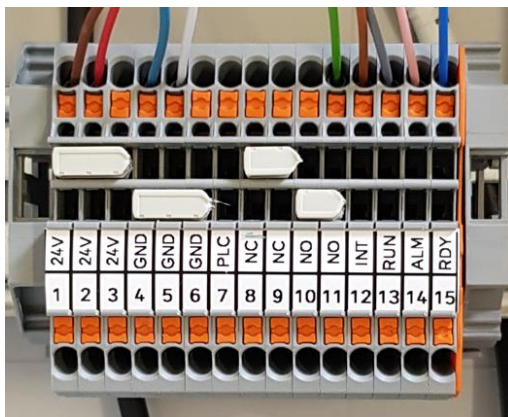
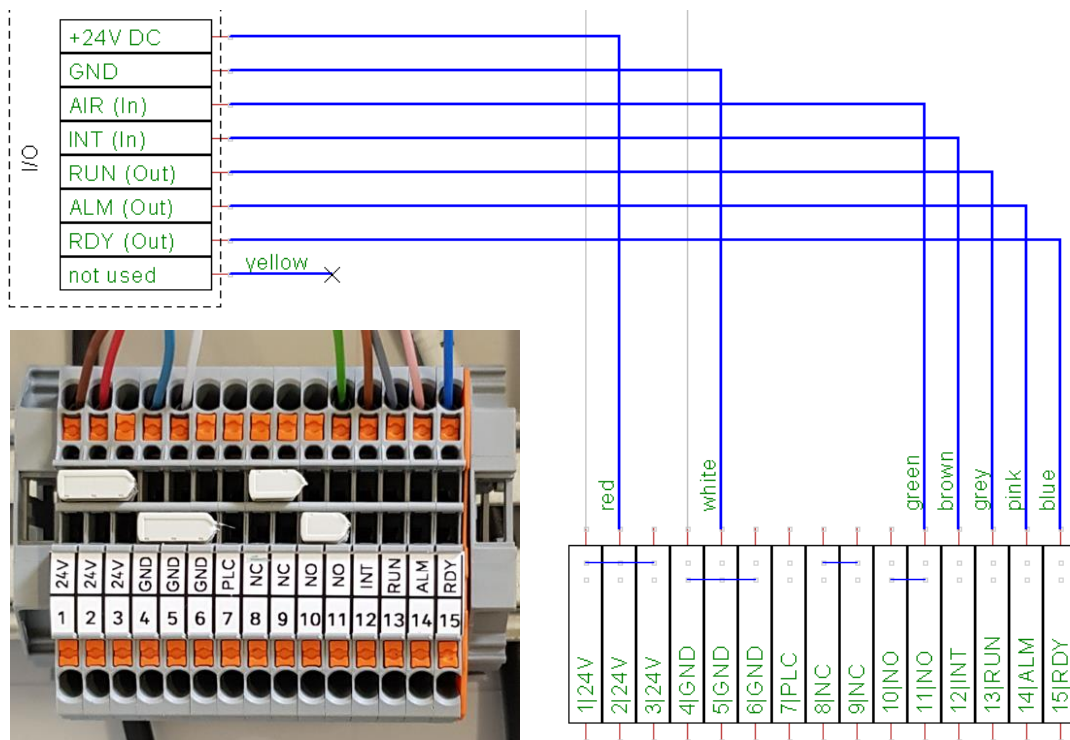

Function	PLX I/O	Control Box Terminal
+24V DC	Red	2 24V (not required when PLX connected)
GND	White	5 GND
AIR (IN)	Green	11 NO
INT (IN)	Brown	12 INT
RUN (OUT)	Grey	13 RUN
ALARM (OUT)	Pink	14 ALM
READY (OUT)	Blue	3 RDY
Analog pressure value	/	7 PLC

8. Only for variant without PLX:

If no PLX is used for power supply, the supply can be made either via a PLC with 24VDC or via the universal power supply.

1. via PLC:

Connect your PLC according to step 7. Here the +24V DC connection is to be occupied.

2. via mains (100-230V):

The control box F830421 has a power cable, which only needs to be connected to the mains.

With the F830415 control box, the integrated power supply must be connected to the mains and output side to the terminal. Use one of the terminals 1-3 for the +24VDC connection and one of the terminals 4-6 for the GND connection.

9. Turn on the system and set the pressure point according to the instructions for the system hood.

10. Finally, check all functions over a test run under normal production conditions.

5 Maintenance

5.1 Regular checks

Maintenance intervals for the individual components can be found in the respective manufacturer information.

5.2 Cleaning

Cleaning instructions for the individual components can be found in the respective manufacturer's information.

6 Spare parts and accessories



Pos	Designation	Art.-No.
1	cable for signal light tower	F830419
2	Differential Pressure Transmitters	F830413
3	Cable for pressure sensor	F830420
4	PLX Databus cable (4 pins)	F830417
5	PLX I/O cable (8 pin)	F830418
6	Signal light tower	F830416

7 Electrical diagrams

7.1 Complete connection scheme: PLX / PLC operation

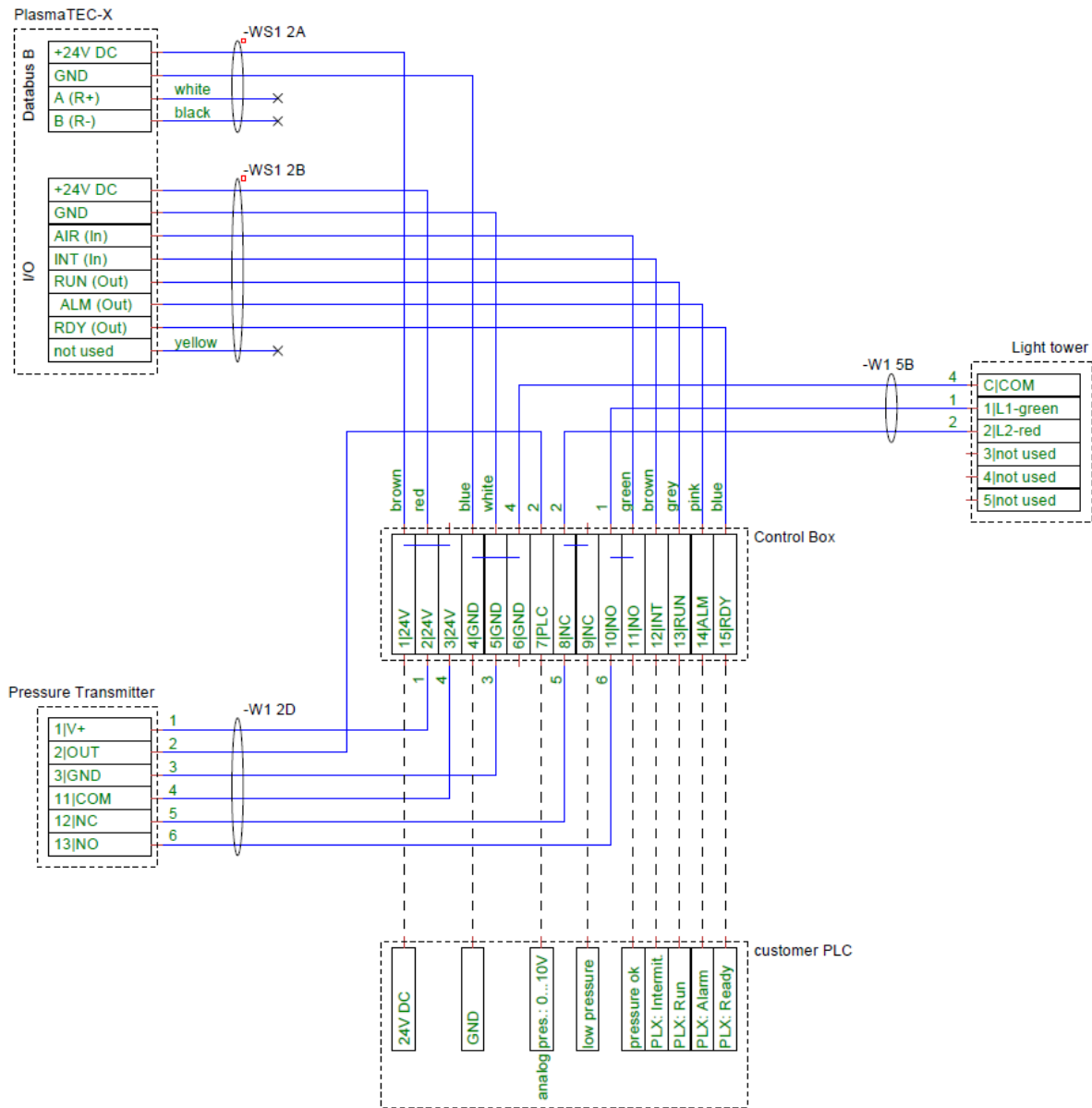

Component	Type	Specification	Order No.	Supplier
PlasmaTEC-X	PlasmaTEC-X	-	PlasmaTEC-X	tantec A/S
Pressure Transmitter	Differential pressure transmitter	0... 1000 Pa, 0... 10 V Analog output	F830414	FlensTech GmbH
Light tower	Light traffic light	24V AC/DC	F830416	FlensTech GmbH
Control box	F830415	-	-	FlensTech GmbH
-WS1 2A	Sensor cable	4x0.34, M12	F830417	FlensTech GmbH
-WS1 2B	Sensor cable	8x0.34, M12	F830418	FlensTech GmbH
-W1 5B	Control line	4x0.5	F830419	FlensTech GmbH
-W1 2D	Control line	7x0.5	F830420	FlensTech GmbH
customer PLC	Customer PLC	-	-	-

7.2 Complete connection scheme: Mains operation

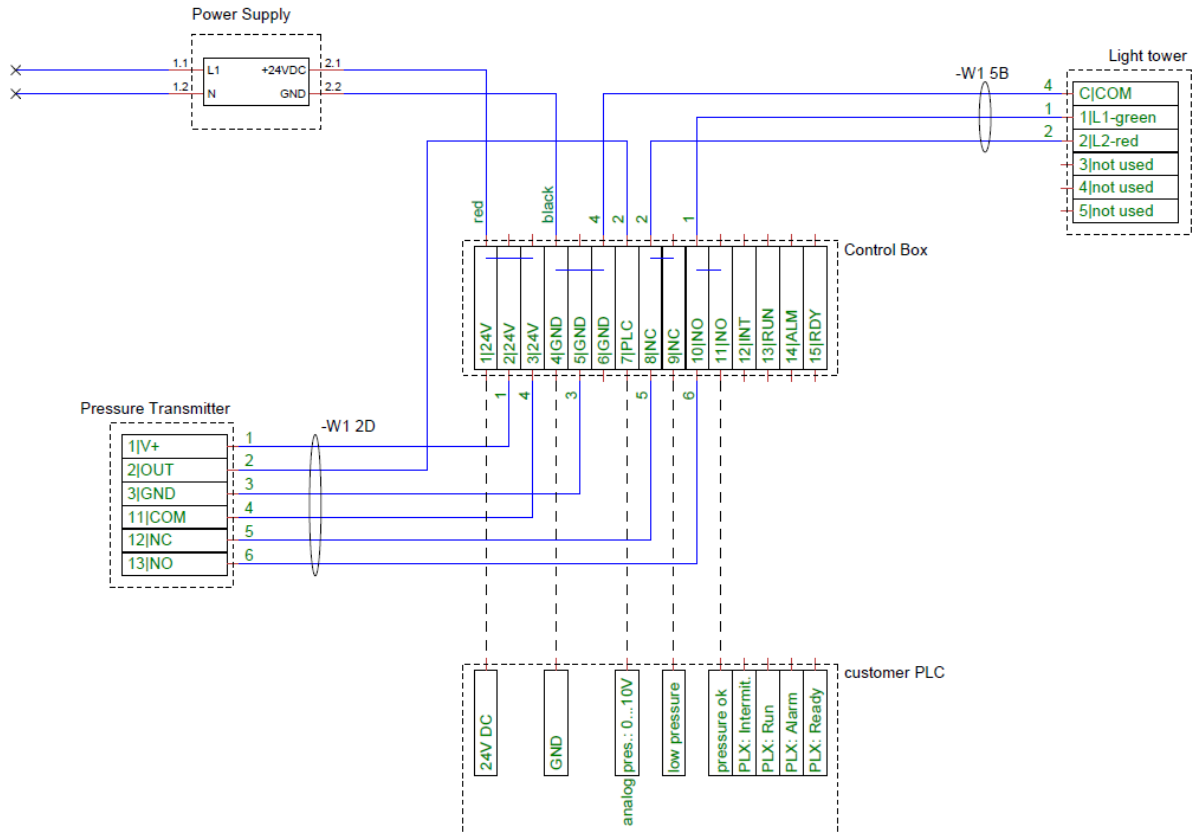

7.3 Detail A: PLX connectors

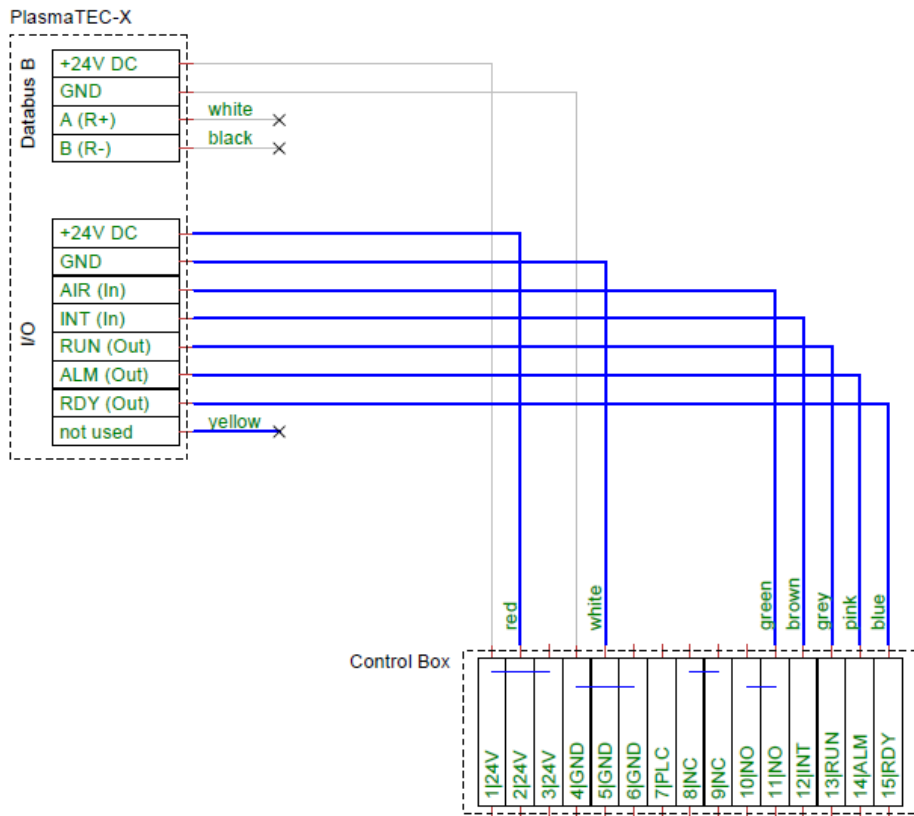
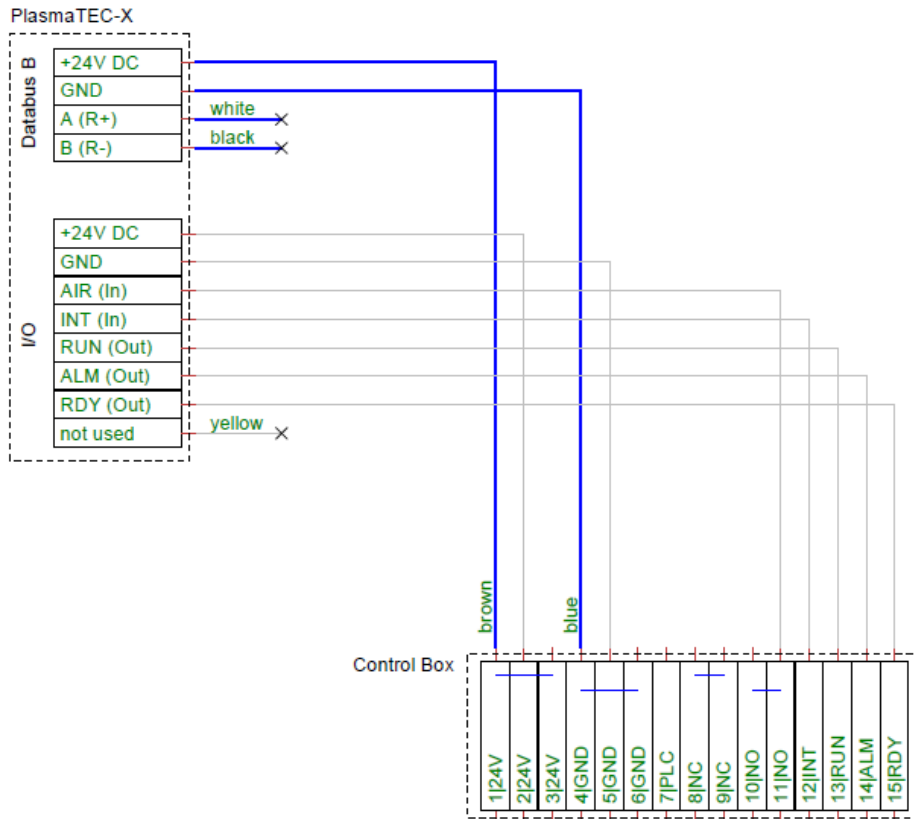

7.4 Detail B: Light tower connections

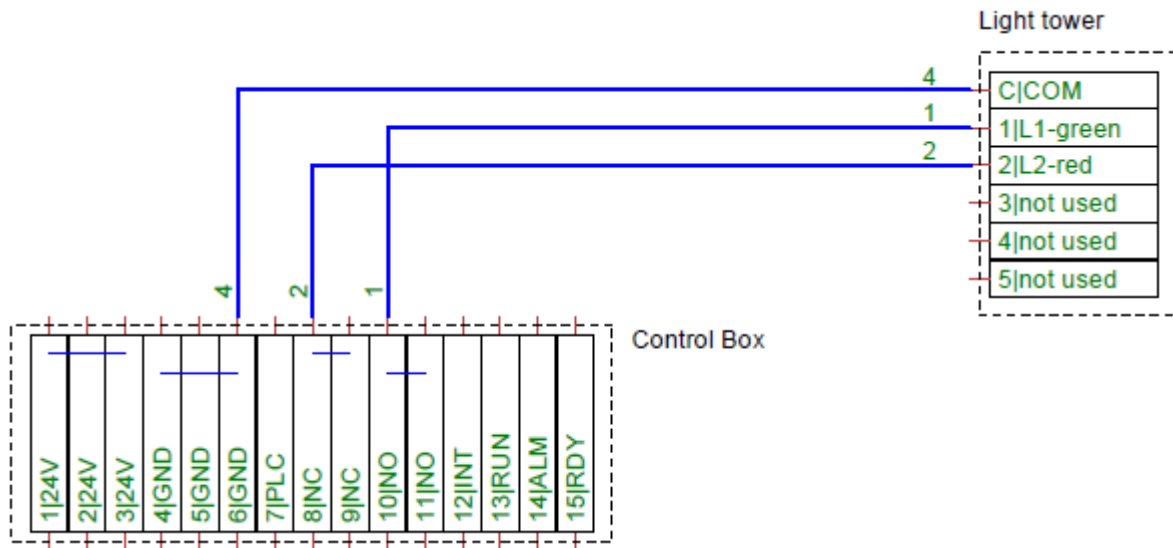

7.5 Detail C: Pressure transmitter connections

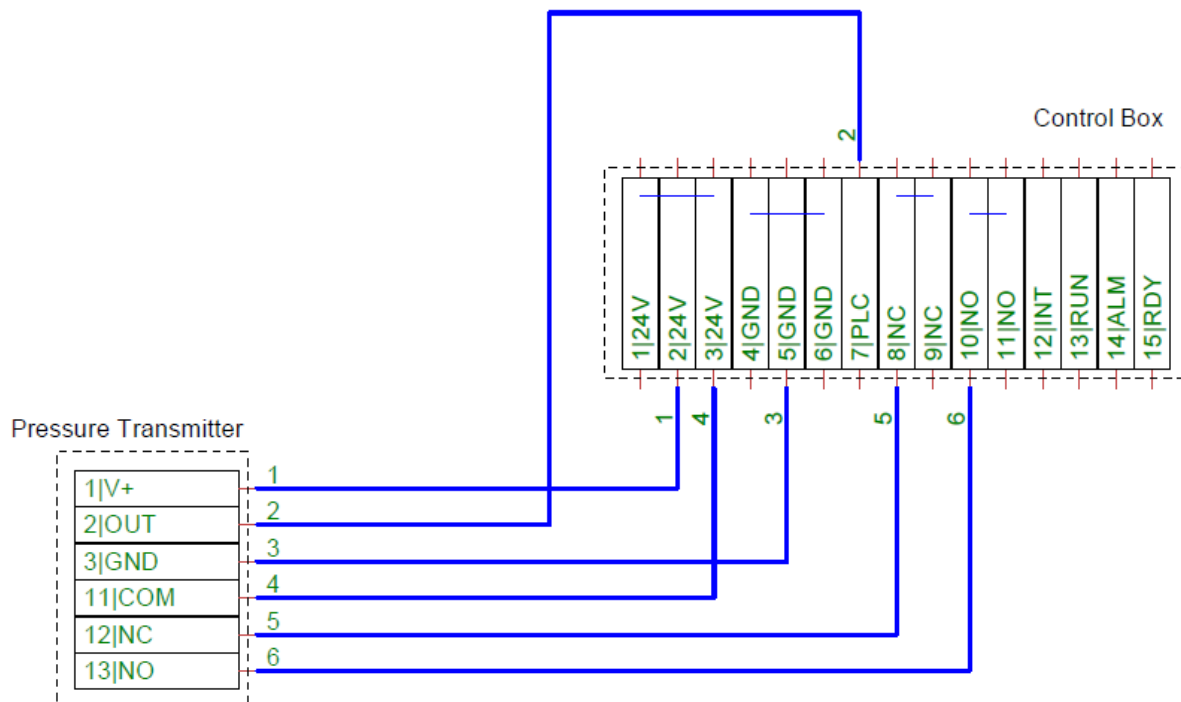

7.6 Detail D: PLC connections



8 Assembly sketches

8.1 Control box

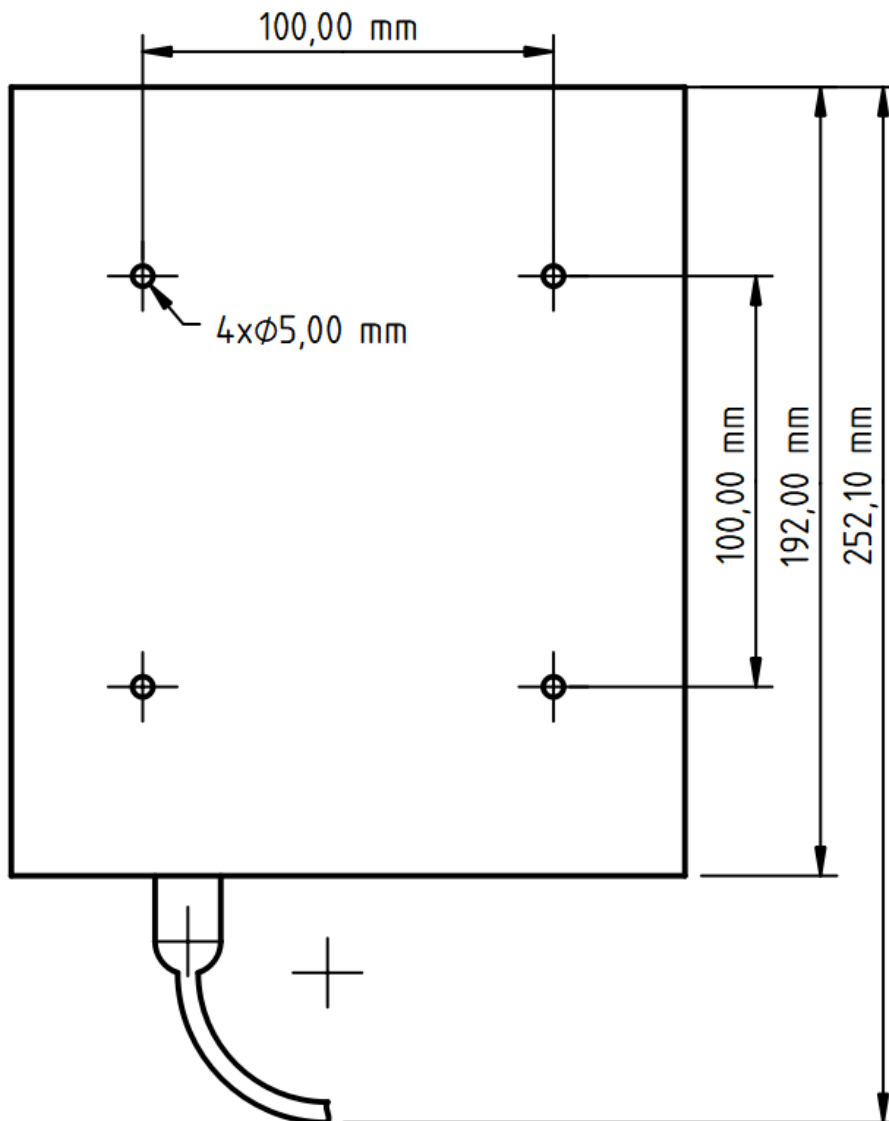

8.2 Differential pressure transmitter and switch

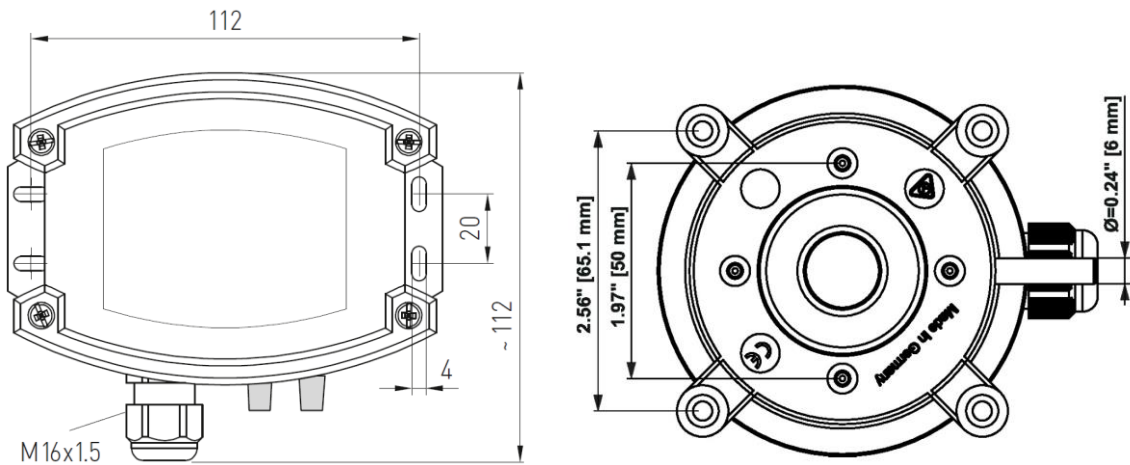

8.3 Light tower and fixing plate

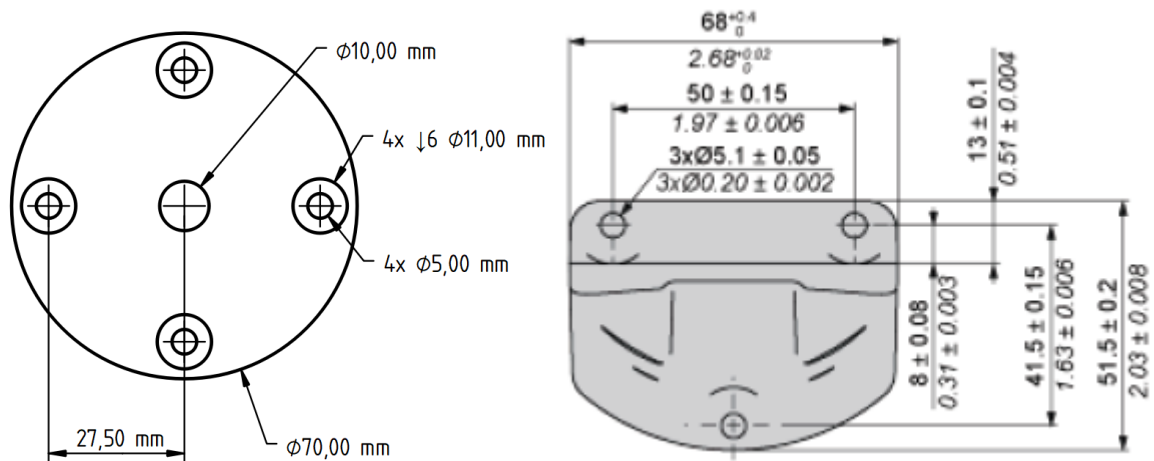

9 Change Log

Versionsnr.	Changes to the predecessor
1.00	First version without predecessor
1.01	8.3 dimensions of fixing plate added